

Applications

- Absorption / transmission / reflection measurement systems.
- Operable as an excitation light source in fluorescence measurement systems
- Eye protection products measurement system
- PEC photochemistry measurement systems
- Solar cell quantum efficiency measurement systems

Features

- Monochromatic light from 300 nm up to 1800 nm
- Collimated, condensed, or coupled output light options. Light can be coupled to any optical system (including fibers and fiber bundles)
- Adjustable optical resolution from 20 nm down to 0.2 nm
- Flexibility of optional features: full automation, various sources and monochromators and more.
- Computer-controlled.



TUNABLE LIGHT SOURCES

Tunable Light Sources

OVERVIEW

Sciencetech offers a series of computer-controlled adjustable sources of monochromatic light, our Tunable Light Source (TLS) line. Each TLS system is pre-aligned at the Sciencetech test lab and packaged with the system's test data and detailed manual. Sciencetech's tunable light sources are motorized instruments controlled by Sciencetech's Windows based software. LabView drivers, ActiveX and DotNet modules are also available making the TLS a flexible system for integration with your experiment or instrument.

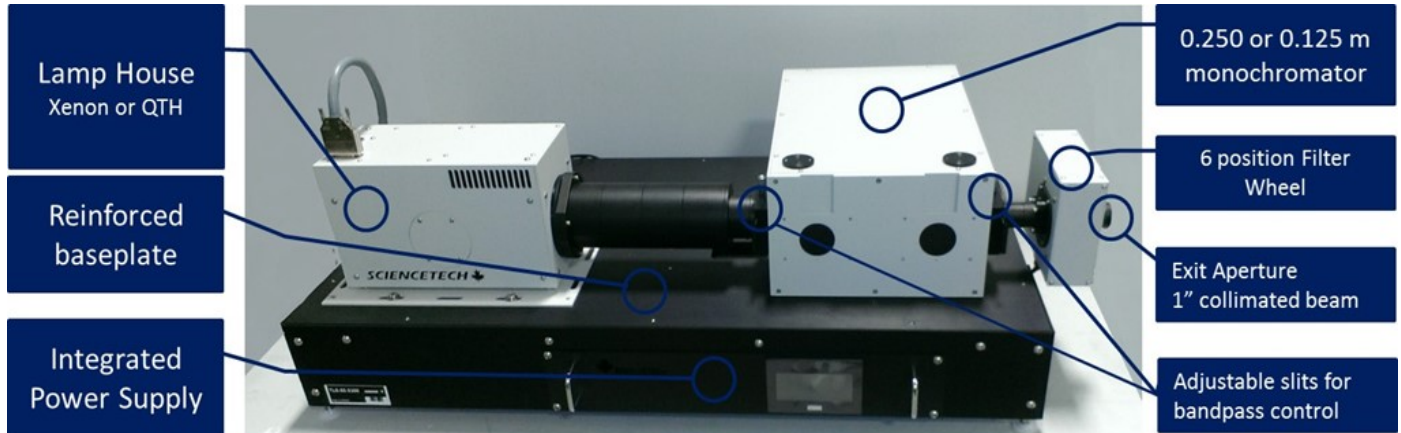

Standard Features

Each base model comes with standard features:

- Sciencetech Light Source Xe or QTH
- 1" optics are used to collimate light output¹
- Sciencetech Monochromator, three-grating turret with two gratings
- Adjustable slits for optical bandpass control
- Motorized filter wheel with 4 long pass filters installed.
- Adjustable computer controlled power supply (Xenon lamps only).
- SciSpec software for controlling the monochromator and filter wheel.
- Reinforced optical base plate.

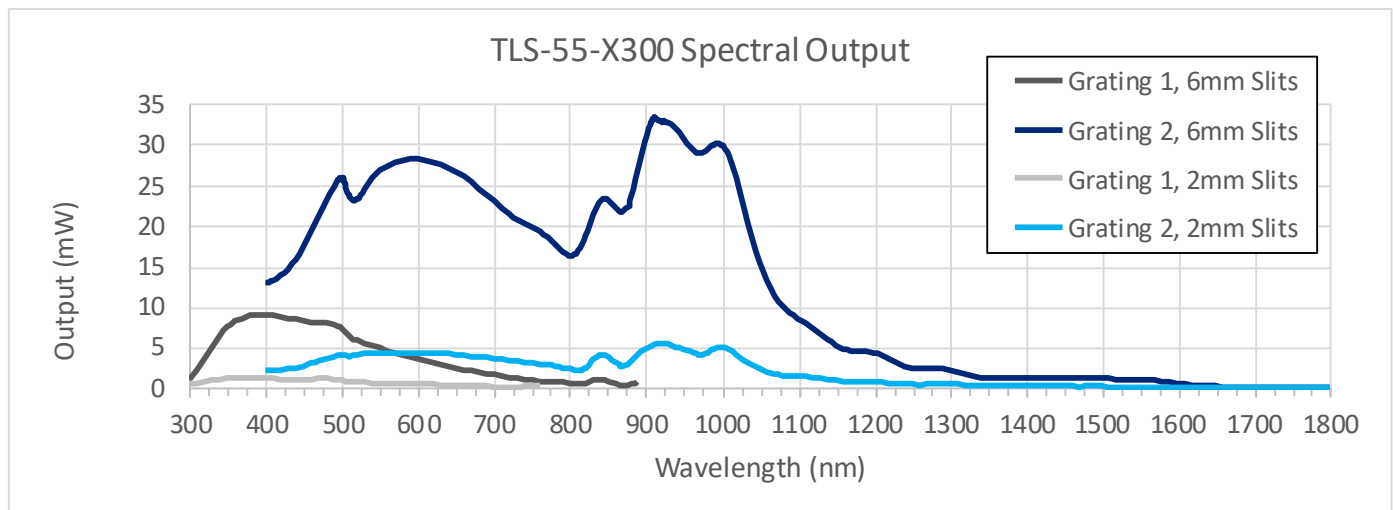

Typical output power of the TLS-X55-300 (Xe lamp 300 W) with various gratings and slits

¹: The collimated beam shape can change depending on monochromator geometry and selected wavelength. To produce consistent beam shape and size at all wavelengths, the addition of a beam homogenizer is recommended.

Tunable Light Sources

SPECIFICATIONS

Sciencetech's software, Sci-Spec, controls all components of the system. In the standard configuration, it controls the power supply of the light source, shutter, filter wheel, and monochromator. As an option, the user can add computer control on the input and output slits, and/or control of the iris. In the standard configuration, the output beam can be collimated or focused. Coupling with different devices is available as an option, such as coupling with a sample chamber, fiber, or fiber bundle.

Customized Solutions

Sciencetech TLS systems are built with modular components making them flexible and adaptable well beyond the standard models offered.

All components of the system, including the light source and monochromator can be customized. Available options include:

- Xe, Xe-Hg and Hg lamps from 75W-1.6 kW
- QTH lamps 50 W-500 W
- Dual deuterium/QTH source
- Mid-IR sources up to 1700 Kelvin
- Available spectral range 180 nm – 10 um (Light source, optics and grating dependent)
- Double subtractive and double additive monochromators
- Monochromators up to 1 meter focal length
- Motorized or manual iris
- Optical light feedback for additional source stabilization (only available with Xe and Xe-Hg lamps)
- Detectors and data acquisition systems can be provided as add-ons
- Can be coupled with Integrating Spheres, samples chambers and other opto-mechanical components upon request

MODELS	TLS-72-X300	TLS-72-Q250	TLS-55-X300	TLS-55-Q250
Lamp Type	Xe 300 W	QTH 250 W	Xe 300 W	QTH 250 W
Monochromator Type	9072S (1/8 meter)		9055 (1/4 meter)	
Functional Spectral Range	300-1800 nm			
Optical resolution	0.5 nm @ 300-450 nm		0.2 nm @ 300-450 nm	
	0.7 nm @ 450-1800 nm		0.4 nm @ 450-1800 nm	
Filter wheel with filter set	Computer-controlled 6-position filter wheel			
Shutter	Optional computer-controlled shutter and exposure control			
Beam output	Collimated with 25 mm [1"] diameter optics ¹			
Wavelength Repeatability	0.1 nm		0.03 nm	
Wavelength Accuracy	0.2 nm			
Intensity Control	Source intensity adjustable. Optional manual iris			
Gratings	2 plane ruled gratings (30x30 mm):		2 plane ruled gratings (50x50 mm):	
	1200 gr/mm@300nm		1200 gr/mm@300nm	
	600 gr/mm@1000nm		600 gr/mm@1000nm	
Bandpass	Two manual bilaterally-adjustable slits with vertical curtain attenuators			
Optical Height	215 mm [8.5"], adjustable +/- 5 mm			
Power supply	Touchscreen, Constant Current	Manual, Constant Current	Touchscreen, Constant Current	Manual, Constant Current
Software	Sci-Spec (Labview examples, DotNet, Active X also available)			
Computer Interface	USB—monochromator and filter wheel, RS232 Power Supply (xenon lamp only)			
Dimensions (mm)	826 × 415 × 320	775 × 416 × 321	927 × 542 × 320	
Weight	30 kg		37 kg	
CE Certification	IEC 61010-1:2010 Safety Requirements for electrical equipment for measurement, control and laboratory use—Part 1			
	IEC 61326-1:2012 Electrical equipment for measurement, control and laboratory use—EMC requirements—Part 1			

1: The collimated beam shape can change depending on monochromator geometry and selected wavelength. To produce consistent beam shape and size at all wavelengths, the addition of a beam homogenizer is recommended.

Tunable Light Sources

OPTIONAL UPGRADES

Various output accessories can be fitted to the monochromator input/output to customize the system for different applications either as a stand-alone unit or to be used in conjunction with other optical devices and systems. Browse the below options to see if any other upgrades and accessories might be required for your application.

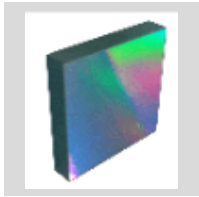

Gratings

Choose the most suitable gratings to be used with your TLS to optimize light output according to your wavelengths of interest.

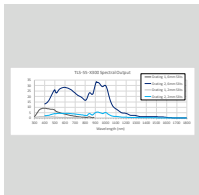

TLS CAL Package

(810-0010)

This service provides light output characterization and optical power emission from 200-1800nm. Also assesses Beam divergence and light source stability.



Motorized Slit(s)

(120-9053)

The SS-80 is a motorized adjustable slit for the input or output port of a Sciencetech monochromator.



Fiber optic light cables

Various fiber optic cables and light guides can be coupled to input or output slits of the tunable light source.



Detectors (Single or multi channel)

Allows the measurement of light at output slits of the system.

Tunable Light Sources

OPTIONAL UPGRADES

Various output accessories can be fitted to the monochromator input/output to customize the system for different applications either as a stand-alone unit or to be used in conjunction with other optical devices and systems. Browse the below options to see if any other upgrades and accessories might be required for your application.



Homogenizing light pipe

Homogenizing light pipes can be coupled to the output slit of the TLS to provide a highly spatially uniform light output on the target.

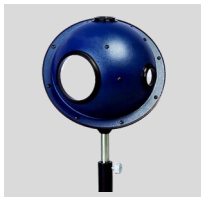

Integrating Spheres

Integrating spheres can be coupled to output slits of the TLS.



Dual input/output slit upgrades

Allow the use of second input/output ports with the use of switching mirrors. Only applicable for TLSs with 9055 monochromators.



Beam splitter

Beam splitters can be installed to split the input or output beams to direct to various detectors and other optomechanical instruments.







Light Intensity Stabilizer

The FS-02-N is an upgrade for the touchscreen power supply and the associated lamp house.

Tunable Light Sources

Output Optics

Sciencetech TLS Systems come standard with 1" collimating optics. A variety of alternative optics are available to suit different irradiance, uniformity, collimation, and beam shape requirements.

Output Optics	Divergence	Uniformity	Irradiance	Beam Shape
Collimated Beam TLS-XX-Q250	collimated	mid	Mid	
Collimated Beam TLS-XX-X300	collimated	poor	Mid	
Homogenized Beam	divergent	good	Mid	
Focused Beam	divergent	poor	High	

Tunable Light Sources

DIMENSIONS

Dimensions are in [mm] and in.

9055 Monochromator-

The dimensions of the Sciencetech Tunable Light Sources vary depending on chosen options and accessories. The base model's dimensions are indicated in mm.

TLS-55-X300

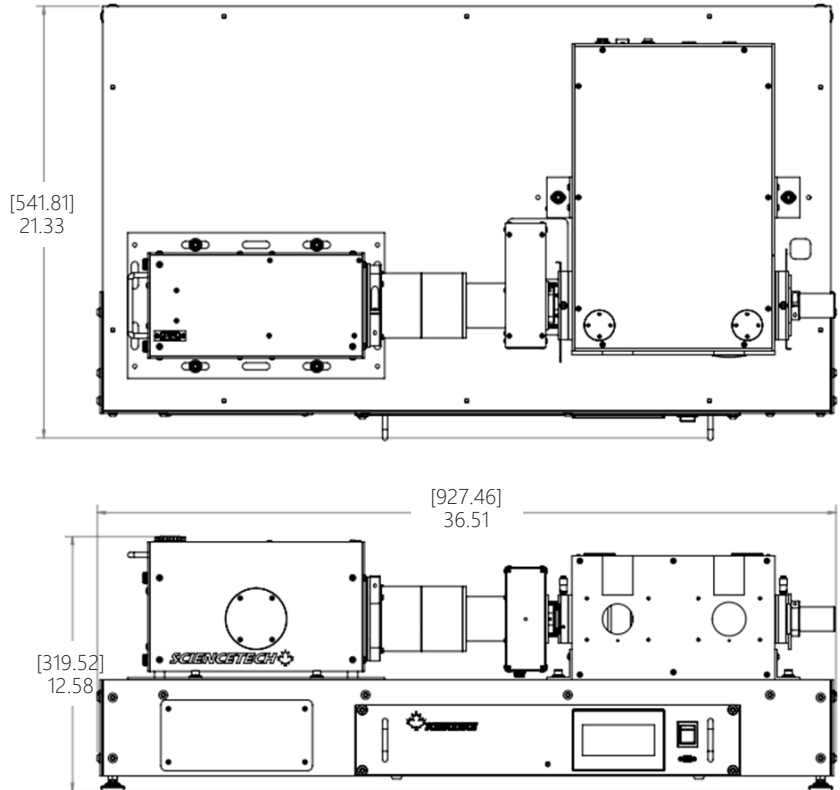

TLS-55-Q250

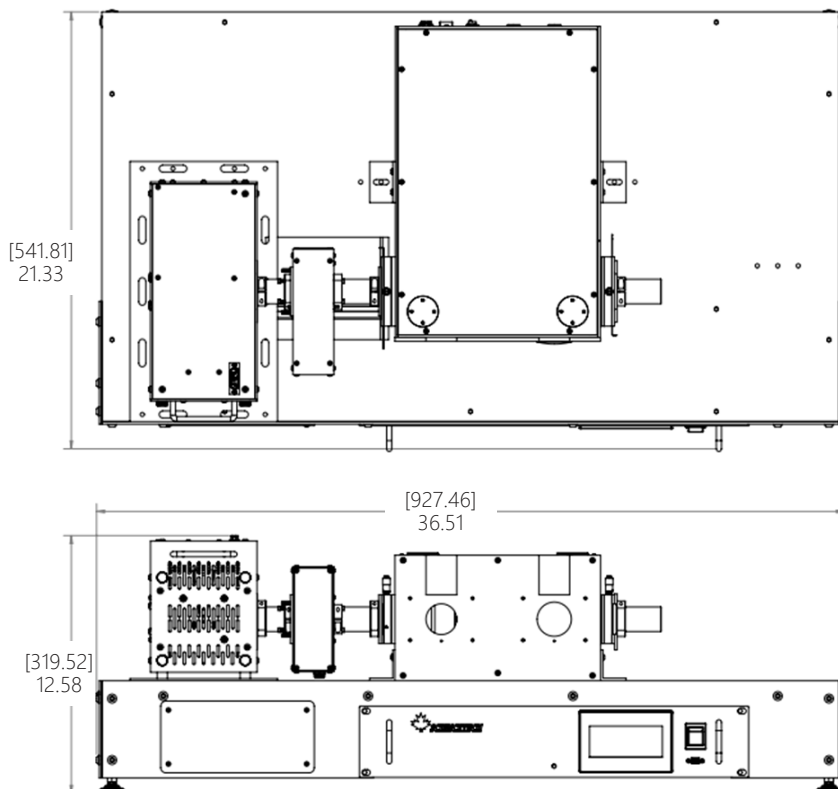

Tunable Light Sources

DIMENSIONS

Dimensions are in [mm].

TLS-72-X300

9072 Monochromator-Based:

The dimensions of the Sciencetech Tunable Light Sources vary depending on chosen options and accessories. The base model's dimensions are indicated in mm.

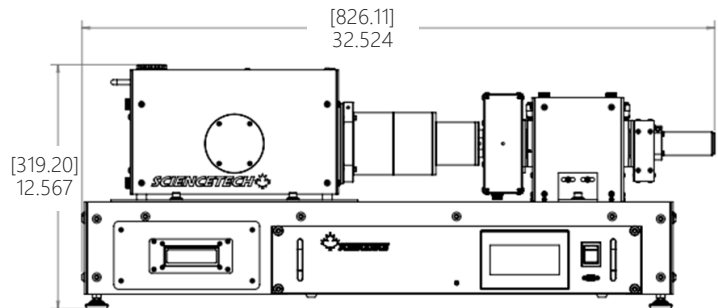
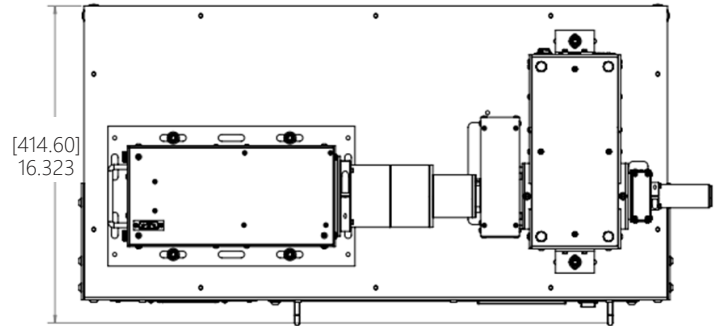

TLS-72-Q250

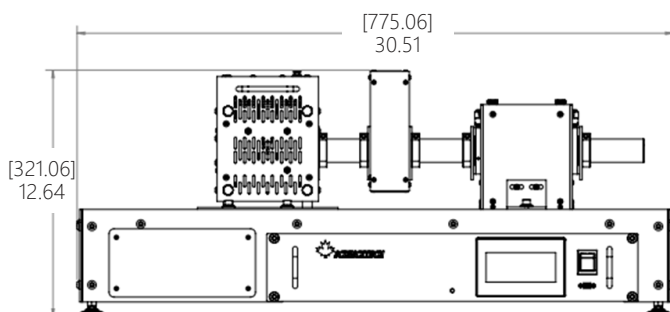
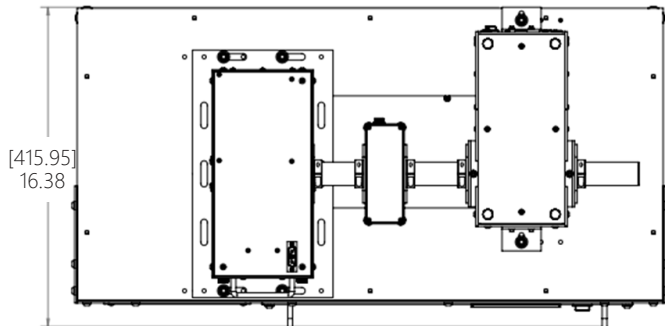

For TLS-55-X300-SS dimensions, please contact a Sciencetech Application Scientist.